

Original Article

IOT Based Salt Content Monitoring System In Watertank

R. Esakki muthu¹, Mr.G.Baskar singh², B. Arunkumar³

UG Student, Department of Civil Engineering, P.S.R. Engineering collage, sivakasi, Tamilnadu, india 626140

Assistant professor, Department of Civil Engineering, P.S.R. Engineering collage, sivakasi

UG Student, Department of Civil Engineering, P.S.R. Engineering collage, sivakasi, Tamilnadu, india 626140

Abstract : In home, agricultural, and industrial settings, where a high salt content can cause major health problems and equipment damage, water quality is vital. An Internet of Things (IoT)-based system for real-time salt concentration monitoring in a water tank is presented in this project. To precisely determine the salinity level of water, the system makes use of conductivity or Total Dissolved Solids (TDS) sensor. A microcontroller, such as an Arduino or ESP8266/ESP32, processes the gathered data before sending it via Wi-Fi to a cloud platform. Through a web dashboard or mobile application, users can keep an eye on the salt levels from a distance. Additionally, the system has alert mechanisms that allow users to take prompt corrective action when the salt concentration surpasses predetermined safe limits. Advanced monitoring and control systems have been made possible by the Internet of Things (IoT) in a number of industries, including water quality management, healthcare, and food safety. An Internet of Things (IoT)-based salt content monitoring system that tracks and measures salinity levels in real time is presented in this project. To determine the amount of salt in liquids or solutions, the system uses a conductivity or salinity sensor interfaced with a microcontroller, such as an Arduino or ESP-based module. Benefits of the suggested system include low cost, ease of deployment, remote accessibility, and real-time monitoring. The system increases productivity, decreases manual intervention, and strengthens safety and quality control decision-making by combining IoT technology with sensing mechanisms.

Keywords : Internet of Things (IoT), Salinity Monitoring, Salt Content Detection, Conductivity Sensor, Water Quality Monitoring, Real-Time Monitoring.

I. INTRODUCTION

Agriculture, industrial processes, and human survival all depend on water. But the availability of water is just as important as its quality. Excessive salt content can render water unfit for drinking, irrigation, and other industrial uses, making it one of the main issues with water quality. Elevated salinity levels can cause health issues, deterioration of the soil, and harm to household appliances.

Conventional water quality testing techniques are frequently labor-intensive, manual, and do not yield real-time data. The development of the Internet of Things (IoT) has made it feasible to continuously and remotely monitor environmental parameters. Real-time data collection, transmission, and analysis are made possible by IoT-based systems, which enhance productivity and decision-making.

The goal of this project is to create an Internet of Things-based salt content monitoring system for water tanks. The system measures the water's salinity using sensors like conductivity or Total Dissolved Solids (TDS). After processing the sensor data, a microcontroller uses wireless communication technologies to send it to a cloud platform. Users can monitor water quality at any time and from any location by using computers or smartphones to access the data.

Effective and dependable monitoring systems are required due to the growing demand for quality control in food, water, and industrial processes. In many applications, including drinking water management, agriculture, aquaculture, and food processing, salt content, or salinity, is a crucial factor. Crop productivity, product quality, and human health can all be impacted by excessive or insufficient salt levels. Conventional techniques for determining salt content are less appropriate for ongoing monitoring since they are frequently labor-intensive, manual, and require laboratory analysis.

II. LITERATURE REVIEW

A. Gandla (2020)

According to the research by Pasika and Gandla (2020), the primary objective of an IoT-based water monitoring system is to provide a low-cost, real-time solution for assessing water safety without the need for manual laboratory testing. The study emphasizes the integration of multiple sensors—specifically pH, turbidity, and Total Dissolved Solids (TDS)—connected to an at-core microcontroller (like the ESP8266). By leveraging Wi-Fi connectivity, the system transmits sensor data to a cloud-based interface, enabling users to monitor salt content and contamination levels remotely via mobile or web applications.

Furthermore, the authors highlight that the system's effectiveness relies on its ability to trigger instantaneous alerts when water parameters deviate from safe thresholds. The literature focuses on the practical application of this system in both domestic and industrial water tanks, where maintaining specific salinity and purity levels is critical for preventing health risks and equipment corrosion. By utilizing an open-source IoT platform, the study demonstrates that high-precision monitoring can be achieved at a fraction of the cost of traditional methods, making it accessible for wider deployment in smart city infrastructures.

In their 2025 study, Mathubala, R. S., et al. present an advanced IoT-based water monitoring and conservation framework designed to bridge the gap between urban and rural infrastructure. The research focuses on a multi-sensor approach that integrates salinity (TDS) sensors with ultrasonic level sensors to provide a holistic view of water tank health. A significant contribution of this work is the emphasis on hybrid communication; the authors demonstrate how combining GSM modules for SMS alerts with standard Wi-Fi protocols ensures that critical salt content data reaches the user even in areas with unstable internet connectivity.

B. Mathubala (2025)

Beyond mere monitoring, Mathubala et al., explore the integration of automated control mechanisms within the IoT ecosystem. Their literature details a system capable of automatically shutting off supply valves or activating filtration units when the salt concentration exceeds pre-defined safety limits (TDS>500 ppm). This proactive management strategy is highlighted as a vital tool for water conservation, as it prevents the wastage of contaminated water and protects domestic appliances from the long-term corrosive effects of high mineral content, effectively transforming a passive tank into a "smart" storage node.

C. Methodology (Workflow)

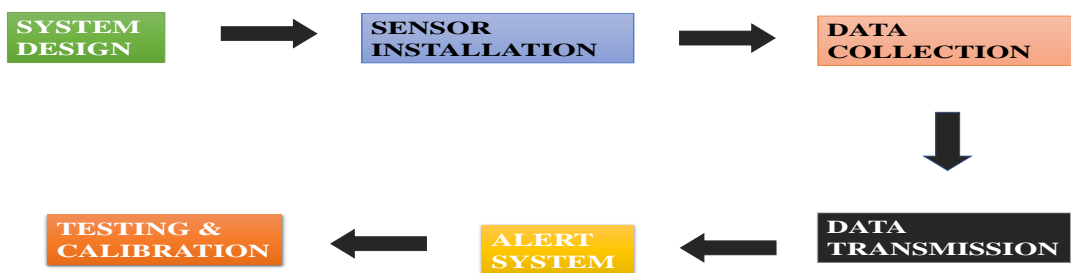

Materials:

- ❑ TDS / Salinity Sensor

Function:

Measures Total Dissable Solids (TDS) in water
 Indicates water quality & salinity level
 Works based on electrical conductivity

Used in:

Water purification systems

Aquaculture monitoring

Environmental analysis

❑ **ESP32 or NodeMCU**

Function:

Acts as the main controller (brain)

Reads data from sensors

Processes and sends output

Supports Wi-Fi & IoT applications

❑ **Temperature Sensor (DS18B20)**

Function:

Measures water or ambient temperature

High accuracy ($\pm 0.5^{\circ}\text{C}$)

Uses digital signal (1-wire communication)

❑ **OLED Display**

Function:

Displays:

- TDS value
- Temperature
- Status messages

Low power consumption

Works via I2C communication

❑ **5V/12V Power Supply**

Function:

Provides power to entire system

5V → Sensors, ESP32 12V → Pumps, motors (if used)

Design and Working:

Interfacing TDS Sensor with ESP32

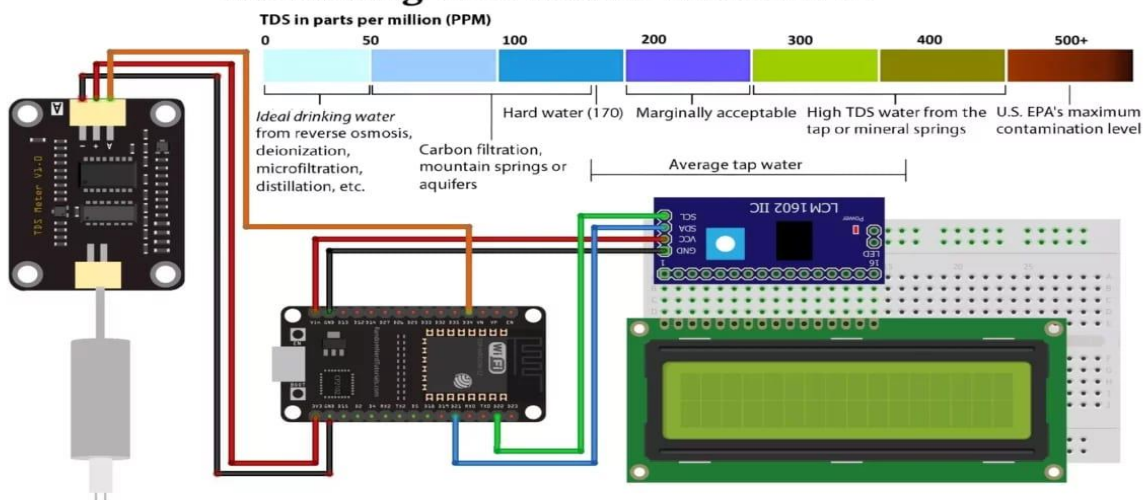

Working Steps:

Sensing Stage:

First, the TDS Sensor Probe installed in the water tank measures the electrical conductivity of the water. If the water contains more salts such as calcium, magnesium, sodium, etc., more electricity will be conducted. This sensor converts it into an analog voltage.

Processing Stage:

This analog signal goes to the ESP32 or NodeMCU microcontroller. The code uploaded to the microcontroller converts that voltage into a unit called PPM (Parts Per Million). For example: \$0 - 300\$ PPM is clean water. If it is more than \$1000\$ PPM, it is salt water (Hard Water).

Local Display & Communication:

The calculated PPM value is immediately displayed on the 16x2 LCD Display mounted there. At the same time, this information is connected to the Internet through the Wi-Fi chip in the microcontroller and sent to the IoT Cloud Platform (Blynk or ThingSpeak).

IoT Monitoring & Alerts:

The user can view the salinity of the water in real-time from anywhere in the world through the app on their mobile phone.

Threshold Alert:

If the salinity exceeds the level you set (for example 800 PPM), the system will automatically send a notification to the mobile and sound a buzzer to alert you.

Future Scope:

Automatic Filtration System:

Currently, your system only monitors the salt level. In the future, you can add a feature that will automatically turn on a Reverse Osmosis (RO) Unit or Water Softener when the salinity level is high.

Multi-Parameter Quality Check:

In addition to salinity (TDS), other important water parameters can be measured

pH Sensor:

To determine the acidity/alkalinity of the water.

Turbidity Sensor:

To determine how cloudy the water is.

Temperature Sensor:

To determine the temperature of the water.

Result:

WATER SAMPLE TYPE	OBSERVED TDS (PPM)	STATUS
Distilled Water	0 – 10 PPM	Pure/Excellent
RO Purified Water	50 – 150 PPM	Good for Drinking
Tap Water	250 – 500 PPM	Acceptable
Ground Water	800 – 1500 PPM	High Salt Content
Salt Mixed water	2000+ PPM	Unsafe/Hard water

III. CONCLUSION

Real-time Monitoring:

This IoT-based system accurately monitors the salinity (TDS) of the water tank 24/7.

User Convenience:

Special Issue: *International Conference on Modern Engineering and Future Technologies (ICMEFT-26)*

No need for manual testing as the user can check the water quality through a mobile app from anywhere.

Health & Safety:

By alerting the user immediately when salinity is high, health problems and pipeline corrosion can be avoided.

Cost-Effective:

Made with low-cost components, it is ideal for homes and small industries.