

Original Article

Bridge Safety Monitoring System Using IOT

¹Mohammed Mehdi Rashidi, ²Mohammed Yousuf, ³Dr. Mubarak Jawahar Ali Khan

¹Department of Computer Applications, Amirkabir University, Tehran Iran.

²Department of Computer Applications, Amirkabir University, Tehran Iran.

³Associate Professor, of Department Computer Applications, Amirkabir University, Tehran Iran.

Received Date: 30 May 2021

Revised Date: 03 July 2021

Accepted Date: 13 July 2021

Abstract: In this examination, a Bridge wellbeing checking framework utilizing IoT is created utilizing remote innovation. The assistance of progression in sensor innovation has brought the computerized continuous extension wellbeing checking framework. This framework will help the avoidance in calamity the board and recovery. IoT-based scaffold security observing framework is created utilizing remote innovation. Different kinds of information can be gathered by utilizing remote sensor hubs like vibration, water level, and extension weight. This information would likewise be valuable for observing and reconnaissance. The main principle of this work is to foster a framework that can forestall mishaps or flyovers primary fiascos and scaffolds. This investigation gave the study of different strategies used to screen the states of the scaffolds and this framework for observing nonstop constructions and an ultrasonic sensor for checking the water level in the stream to keep away from traffic from an extension in flood utilizing Kalman's channel calculation. In the event of crisis circumstances, the extension entryways will be shut consequently. The gathered information is communicated to the worker and the data set for administrators to observe the scaffold conditions through portable telecom gadgets continuously.

Keywords: Bridge Safety, Water Level Sensor.

I. INTRODUCTION

Presently, it is vital to screen the extensions in our nation or state, as frequencies happen prior. The purpose of these occurrences is that there is no such framework, which will offer data to the people groups if the scaffold isn't in acceptable condition when unexpected circumstances may happen like flood or quake. It implies that the extension isn't in a safe condition. When this sort of circumstance emerges, the scaffold might be a breakdown, which causes many misfortunes like mishaps, human passings, and so on. There is no productive framework in presence and warned about conditions about the current state of the scaffold when the extension isn't in protected mode. In the current frameworks, Zig-Bee innovation is utilized, which is cost-devouring and very tedious. However, this framework utilized the TCP/IP convention, which is appropriate for a wide range of scaffolds.

Hence in this examination, the IOT remote sensor organization and brilliant structure innovations are embraced to take care of the different issues of extension security data transmission and the board by fostering an IOT based scaffold wellbeing checking framework equipped for observing the ecological information of a scaffold and sending the information to the cell phones of scaffold security the executive's staff for reference and documentation

II. RELATED WORKS

With the improvement of data innovation, the Internet of Things has solid penetrability, enormous utilization of activity, and great extensive advantages. It advances the improvement of the Internet of Things innovation in recognition of primary designing. It is helpful for the advancement of astute, refined, and arranged designs [1].

The break is the most widely recognized danger to the security of extensions. Chronicled information shows that the wellbeing mishaps brought about by breaks represent over 90% of the all-out connect catastrophes. After a significant stretch of designing practice and thorough hypothetical examination, it was tracked down that 0.3 mm is the most extreme passable for connecting breaks. On the off chance that the width surpasses the breaking point, the trustworthiness of the scaffold will be eradicated, and surprisingly a breakdown mishap will happen. Consequently, distinguish breaks in connect structure adequately and give powerful data to primary fiasco decrease projects in time.[1]

Overall, we failed to close the valve or direct during the time spent filling the water holder, so water is pouring out, and the water is wasted. For that reason we propose to use the Internet of Things thought that can deal with the issue [2]. This model utilizes a controller of ESP8266 that can give the actually looking at level of the water holder. That controller will open and close the siphon or valve normally, so the water isn't gushing out and wastes. We



use an ultrasonic sensor to distinguish the level of the water. We utilize the Blynk IoT organization intertwined with PHP web programming in giving water-level checking and control. We have given the system a shot a 64 cm water holder. The system has a bungle of 2 cm in controlling the water level.

The transportation of China created [3] quickly as of now. The number of different sorts of extensions, boat's weight, and route speed had constantly been expanding, and the impact mishaps of boat and scaffold often occurred. The goal was to set up a scaffold waters region transport security route framework to consequently distinguish the boats cruising track and guide the route utilizing GPS, remote organization, installed innovation and prescient control advances based on connecting waters wellbeing natural appraisal and investigation [4] of the elements influencing the boat securely through the extension, which can be utilized to decidedly forestall and stay away from the mishaps.

III. PROPOSED SYSTEM

This segment introduced the proposed arrangement of the paper. Figure 1 clarifies the information Share among extension and observing Center is happened using WI-FI module. It can be used to cut off through which status of the state of extension is communicated to the observing Center. The Observing gadgets like the level of water, vibration sensor and then the weight sensor persistently check the primary soundness of extension. On the off chance that level of water is expanded and assuming extension is vibrated, boundaries with a closed servomotor and simultaneously, the scaffold status is coordinated to the observing Center.

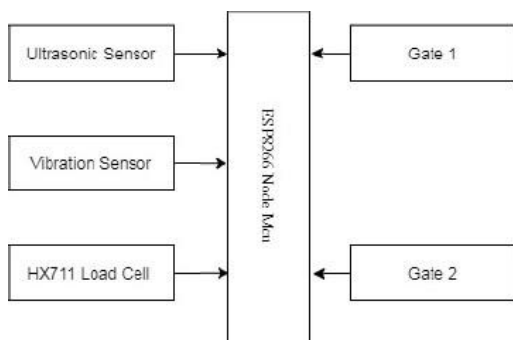

Figure 1: Proposed Model

ESP8266 Nodemcu

The ESP8266 is a miniature regulator with an Inbuilt Wi-Fi to connect the gadget to the web. It has 1 simple and 11 information to interface numerous sensors in a solitary framework

Water Level Sensor

Ultrasonic used to identify the substances degree which incorporates a fluid, granular, slurries and powders. It can be transported to measure inside a shut compartment or the water progression.

Vibration Sensor

A vibration sensor is used to estimate, show, and break down the speed, uprooting, closeness, or speed increase.

Weight sensor

The HX711 Amplifier Module is utilized 24 high-exactness ADC chip hx711, is intended for high-accuracy with two simple information channels. It was also coordinated with multiplier and utilizes a clock and Data respectively.

Servomotor

A servo motor is controlled by a servomechanism. This motor is based on a DC, then, at that point, it's ordinarily alluded to as a DC Servo Motor. The AC works the controlled engine that is alluded to as an AC Motor.

Benefits

- To give wellbeing to spans.
- To keep away from mishaps in the event of awful climate conditions.
- To further develop scaffold proficiency.
- To defeat the specialized and cost snags

IV. RESULT AND DISCUSSION

This section is presented the proposed performance result.



Figure 2: Overall Application



Figure 3 Water Level

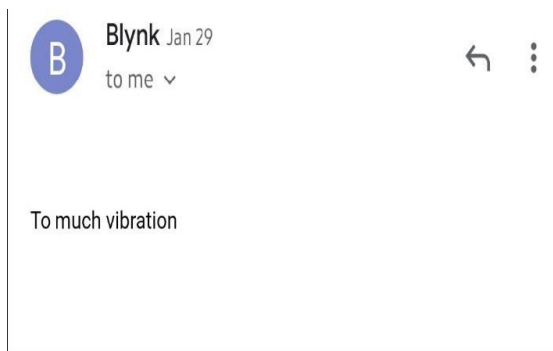

Figure 4 Vibration Notification



Figure 5 water level notification

V. CONCLUSION

Bridge health condition monitoring is a famous issue. This model is consistent and condition has an simpler and exact result. The water level and remote innovation is creating for getting spans in this new technology. It can be used to check the water level and the extension for security reasons. Some of the situations like a flood, tremor and the message are included. This System is extraordinary in its screen capacity the scaffold climate. It imparts normal data through far off correspondence and sends alerts to the expansion of the board staff, for instance, Observing Center logically for brief action also to clients. The key objective of a Bridge Monitoring System using IOT is to save people's presences and safeguard them from the setback.

REFERENCES

- [1] Liyan Zhang, Guanchen Zhou, Yang Han, Honglei Lin, Yuying Wu, "Application of Internet of Things Technology and Convolutional Neural Network Model in Bridge Crack Detection", IEEE Access (Volume: 6), Page(s): 39442 – 39451, ISSN: 2169- 3536.
- [2] Dianhu Du, "Study on the bridge-waters area ship safety collision avoidance navigation system", 2018 Chinese Control And Decision Conference (CCDC), ISSN: 1948-9447
- [3] Dianhu Du, "Study on the bridge-waters area ship safety collision avoidance navigation system", 2018 Chinese Control And Decision Conference (CCDC), ISSN: 1948-9447.
- [4] Y. R. Risodkar; A.S. Pawar," A survey: Structural health monitoring of bridge using WSN"2016 International Conference on Global Trends in Signal Processing, Information Computing and Communication, 2017
- [5] Chae, M. J., Yoo, H. S., Kim, J. R., Cho, M. Y. "Bridge Condition Monitoring System Using Wireless Network (Cdma And Zigbee)" ISARC, 2006.
- [6] M. T. Lazarescu, "Design of a WSN Platform for Long-Term Environmental Monitoring for IoT Applications," in IEEE Journal on Emerging and Selected Topics in Circuits and Systems, vol.3, No.1, March 2013, pp.45-54.

- [7] P. Daponte, F. Lamonaca, F. Picariello, L. De Vito, G. Mazzilli, I. Tudosa, "A Survey of Measurement Applications Based on IoT," 2018 Workshop on Metrology for Industry 4.0 and IoT, Brescia, 2018, pp.1-6.
- [8] E. Balestrieri, L. De Vito, F. Lamonaca, F. Picariello, S.Rapuano, I.Tudosa, "Research challenges in measurement for Internet of Things systems," ACTA IMEKO, vol.7, No.4, Dec. 2018, pp.82-94.